

**LD-LHTE01**  
**Manual assembly, loading, tapping, testing, and plating all-in-one machine**

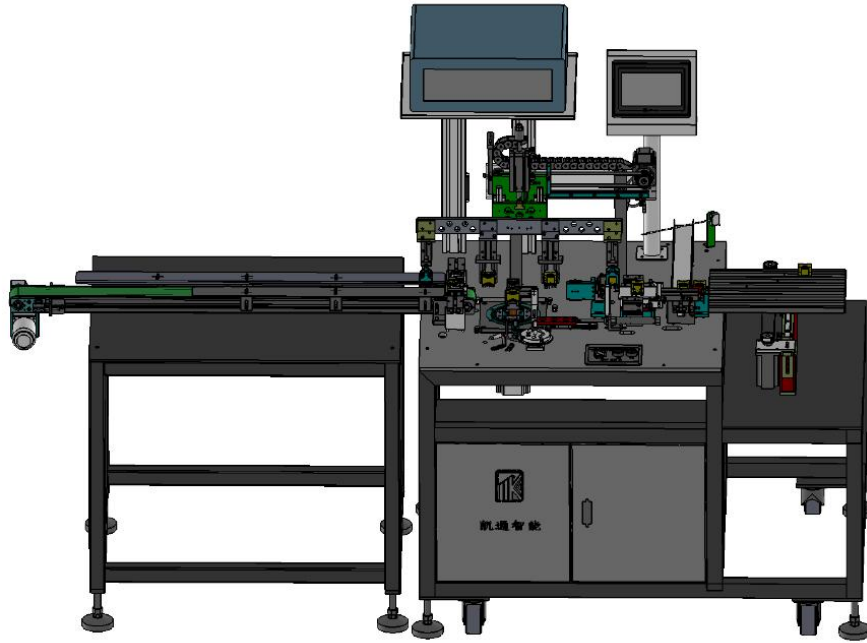

**Machine station diagram:**

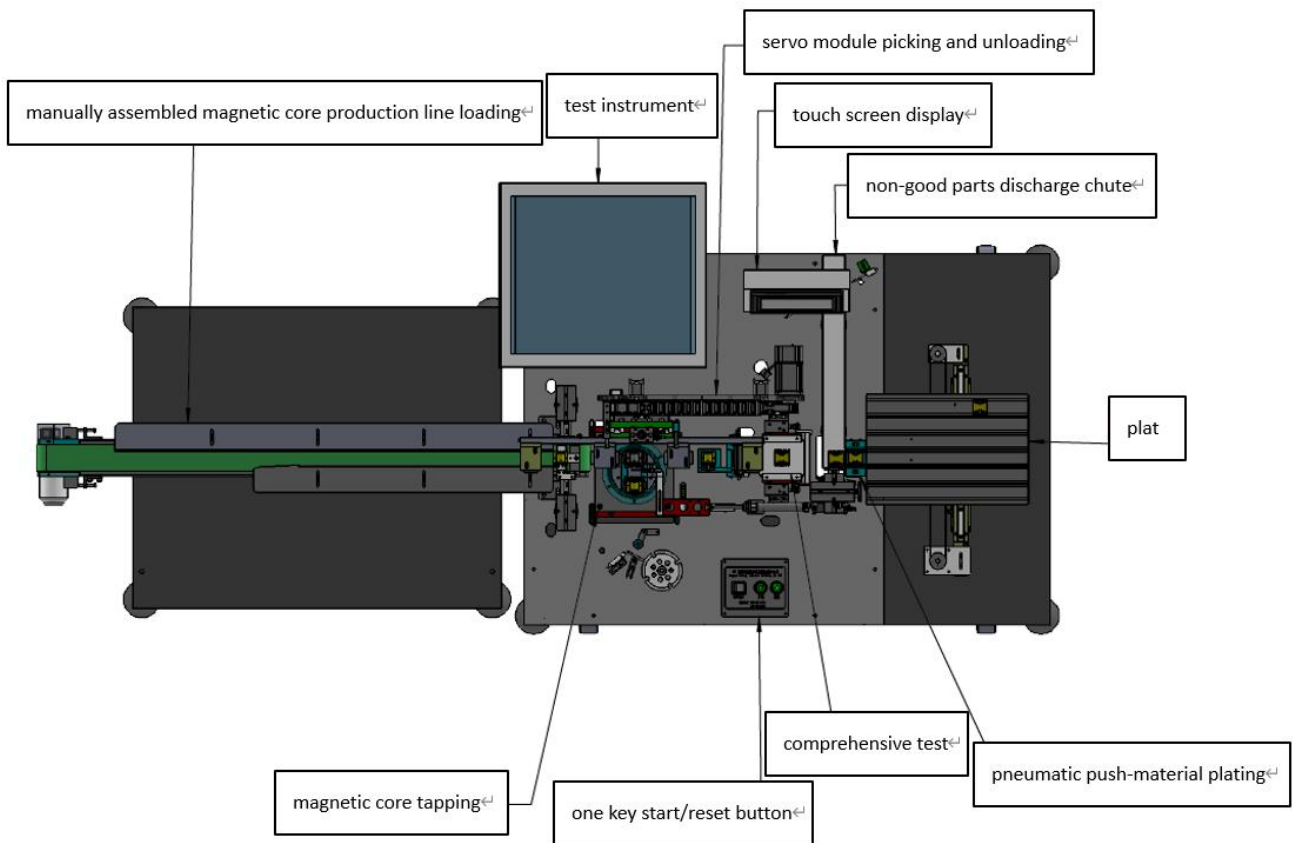

**Operation process:**

Manual assembly loading>tapping>testing>plating

**Equipment Specifications:**

Loading/unloading method	Manual loading plating, Automatic unloading plating
Test instrument	Customer-supplied (equipment provides standard connectors)
Applicable Bobbin Type	EI、EE、EF、EPC、ER、RM、PQ
Size range	10~35mm(The corresponding fixture needs to be replaced when switching products)
Average production efficiency	1200pcs/hour.
Total power used	600W
Power supply	220V 50HZ
Gas source	0.6~0.8Mpa
Machine size	L2200*W1000*H1300mm
Machine weight	About 200KG

Applicability: Products of different sizes can share the machine by changing the fixture.